



MB550/MB550P

VIDEO WHEEL BALANCER
WITH CUTTING-EDGE TECHNOLOGY



MB550/MB550P VIDEO WHEEL BALANCER WITH CUTTING-EDGE TECHNOLOGY

- 🇬🇧 M&B MB550/550P is the video balancing machine with cutting-edge technology
- 🇮🇹 M&B MB550/550P è l'equilibratrice video con funzioni tecnologiche di ultima generazione
- 🇫🇷 M&B MB550/550P est l'équilibriseur de roue vidéo avec fonctions technologiques de dernière génération
- 🇩🇪 M&B MB550/550P ist die video Auswuchtmaschine mit modernster Technologie
- 🇪🇸 M&B MB550/550P es la equilibradora de ruedas video con funciones de última generación



INNOVATIVE SOFTWARE



AUTOMATIC APPROACH to the correction position. Once the measuring launch is completed, the wheel automatically stops close to the exact point of application of the counterweight, allowing the operator to position it correctly with a little movement. So it facilitates and speeds up the calibration procedure. After the first plane correction, pressing "start" the wheel will be repositioned around the second correction point



AUTOADAPTIVE software detects wheel weight and dimensions and calculates the tolerance value that will cancel any vibration perceived on the steering wheel, granting the highest comfort when driving

- UK** **Automatic gauge** for a correct measurement of distance and diameter of rims up to 27" (maximum adjustable diameter 30")
Sonar system for automatic detection of rim width
Laser line for the correct application of stick-on weights and **led light** to illuminate di working space
Automatic approach: automatic wheel stop close to the points of application of correction weights and electric brake to lock the wheel in position
Intuitive and user-friendly **SPLIT, OPT, ALU programs**
AutoAdaptive Mode: detects wheel weight and dimensions and calculates the tolerance value that will cancel any vibration perceived on the steering wheel, granting the highest comfort when driving
Wheel protection guard that allows balancing of 1.120 mm (40") diameter wheels
MB550P: **pneumatic wheel locking** which grants floor to floor time reduction and accurate wheel centering
- IT** **Calibro automatico** per la corretta misura di distanza e diametro di cerchi fino a 27" (diametro massimo impostabile 30")
Sistema Sonar per la rilevazione automatica della larghezza cerchio
Linea laser per la corretta applicazione del peso adesivo e **luce led** per illuminare lo spazio di lavoro
Avvicinamento automatico: arresto automatico della ruota in prossimità dei punti di applicazione del peso di correzione e freno di stazionamento elettrico
Programmi SPLIT, OPT, ALU intuitivi e di facile utilizzo
AutoAdaptive Mode: acquisisce peso e dimensioni della ruota e ricalcola il valore di tolleranza tale da annullare ogni vibrazione percepita sul volante, assicurando il maggior comfort possibile alla guida
Carter di protezione ruota che permette l'equilibratura di ruote aventi un diametro di 1.120 mm (40")
MB550P: serraggio della ruota con **bloccaggio pneumatico** che garantisce una riduzione dei tempi di montaggio ed una maggiore precisione nel centraggio della ruota
- FR** **Calibrage automatique** pour la mesure correcte de la distance et du diamètre des jantes jusqu'à 27"; diamètre réglable maximum 30"
Système Sonar pour la détection de la largeur de la jante
Indicateur laser de positionnement du poids adhésifs et **lumière LED** pour éclairer l'espace de travail
Approche automatique: arrêt automatique de la roue près du points d'application du poids de correction et frein électrique pour bloquer la roue
Programmes SPLIT, OPT, ALU intuitifs et faciles à utiliser
AutoAdaptive Mode: acquiert le poids et les dimensions de la roue et recalcul la valeur de tolérance de façon à annuler toute vibration perçue sur le volant, ce qui assure le meilleur confort de conduite possible
Carter de protection de la roue permettant l'équilibrage de roues ayant un diamètre de 1.120 mm (40")
MB550P: verrouillage de la roue par **bloccage pneumatique**, ce qui garantit une réduction des temps de montage et une haute précision du centrage de la roue
- DE** **Automatischer Messlehre** zur korrekten Messung von Abstand und Durchmesser von Felgen bis 27" (maximal einstellbarer Durchmesser 30")
Sonarsystem zur Erfassung der Felgenbreite
Laserstrahl zur Positionierung des Klebegewichtes und **LED-Licht** zur Beleuchtung des Arbeitsbereichs
Automatischer Ansatz: automatischer Radstopp in der Nähe des Gewichtsanwendungspunkts und Elektrische Bremse zum Blockieren des Rads
Intuitive und benutzerfreundliche **SPLIT-, OPT- und ALU-Programme**
AutoAdaptive Mode: die Software erfasst Radgewicht und -abmessungen und berechnet erneut einen Toleranzwert, mit dem jede am Lenkrad wahrgenommene Vibration ausgeschaltet und somit der bestmögliche Fahrkomfort garantiert werden können
Instandhaltung **Radabdeckung** die das Wuchten von Reifen bis zu einem Durchmesser von 1.120 mm (40") erlaubt
MB550P: **pneumatische Radaufspannung**, die eine Verkürzung der Montagezeiten und eine hohe Genauigkeit bei der Radzentrierung garantiert
- ES** **Calibre automático** para una medición correcta de distancia y diámetro para llantas de hasta 27" (diámetro máximo ajustable 30")
Sistema Sonar para detectar el ancho de la llanta
Linea laser para el posicionamiento exacto de los contrapesos adhesivos y **luz led** para iluminar el espacio de trabajo
Enfoque automático: parada automática de la rueda cerca de los puntos de aplicación de los pesos de corrección y freno eléctrico para bloquear la rueda y facilitar la aplicación de los contrapesos
Programas SPLIT, OPT, ALU intuitivos y de uso fácil
AutoAdaptive Mode: adquiere peso y dimensiones de la rueda, y recalcula el valor de tolerancia para anular cualquier vibración percibida en el volante, asegurando el mayor confort posible en la conducción
Cárter de protección de la rueda que permite el equilibrado de ruedas con 1.120 mm de diámetro (40")
MB550P: apriete de la rueda con **bloqueo neumático**, lo que garantiza tiempos de montaje reducidos y una mayor precisión al centrar la rueda

STANDARD CONFIGURATION



supplied with machines with manual locking



supplied with machines with pneumatic locking



OPTIONAL ACCESSORIES



UH20/2 Ø 40
Universal adapter 3-4-5-6 hole



RL cup Ø 40
with rubber ring for alloy rims protection



J cone Ø 40
for cross-country and
4WD wheels range Ø 101-119 mm



WD spacer Ø 40
(Spacer for wide wheels) + DC spacer
Ø 40 (to use together with WD)



VL/2 cone Ø 40
Large cone for light truck 97-180 mm



Special cone Ø 40 for central
hole Ø 89/132 mm



WBL80
Professional automatic wheel lift
capacity 80 kg

OVERALL DIMENSIONS

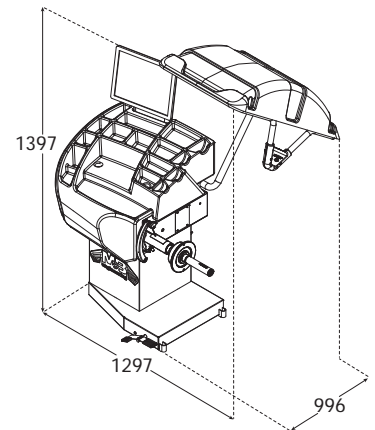
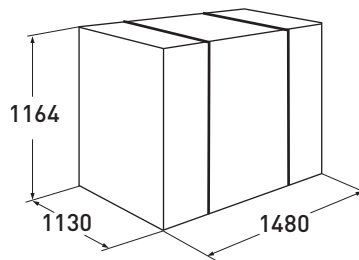

TECHNICAL DATA

120 kg	10" ÷ 30" 265 ÷ 765 mm	1.5" ÷ 20" 40 ÷ 510 mm	20" 508 mm	40" 1120 mm	< 75 kg	230V/1/50-60 Hz 115V/1/50-60 Hz	100 rpm	0,65



M&B ENGINEERING SRL
Via Nobel, 21 - 42124 Reggio Emilia (RE)
info@mb-re.it - www.mbenengineering.info